



INTELLIGENT
DISPLAY
SOLUTIONS

ALL_{in} ONE DISPLAYS
C A T A L O G



XPOZIT

INTELLIGENT
DISPLAY SOLUTIONS

CATALOG

CUPRINS

SERIA HP	10	PANELS
XR Series XS Series XF Series XT Series	16	STRUCTURES
XC SERIES	30	CRADLES
2.0 Series	40	2.0
XT Series	42	SANITARY
XP Series	48	PARQUET
XV Series XC Serie <small>Coolinh & Heating</small> XEL Series <small>Electric</small> XUA & XMA Series	52 54 60 66	TECHNICAL
AMG Series <small>Magnetic Ambient</small>	72	MAGNETIC
M-DIY Series <small>Magnetic System for Shelves</small>	78	

ABOUT US

Our goal at Xpozit is to exceed clients' expectations in terms of their projects.

Either as it refers to showroom displays, shelves, merchandising systems or magnetic panels for changing the existing boards in the locations.

We have 10,000 square meters of workspace at our disposal, located in our factory, with easy access from Bucharest Ring Road.

Xpozit's objective is frankly common.

We constantly try to offer our clients the chance to benefit from quality and promptitude, keeping an ongoing partnership with them through the sales department.

We always explore the customers' needs, and as a result, we are able to identify the best solutions.

We constantly try to blend imagination with engineering harshness and quality with innovation.

This is how Xpozit can be so different on the market.

We know that each client, each brand, and each project is unique. For this reason, we propose a tailor-made design solution for each of them, trying to fit them most properly. Ultimately, our product needs to suit project characteristics and customer style perfectly.

We carefully pick up all the details from our clients. After we gathered all the information, emotions and ideas behind the project, we are ready. And all of that guide us to a perfect creative process capable of spreading the customer message into the market in the most effective way.

Xpozit offers a complete line of displays with a metal structure, synoptic panels, mobile panels, floor displays, shelves and ceramic tiles.

We also provide a turnkey solution for all services that our clients may request, from surveys and market studies to project enactment in locations and maintenance for the delivered products.

Here at Xpozit, we have no limits!

Our organization is extremely flexible and well-prepared to allow the manufacturing and delivery of any order.

We don't have "a minimum limit" in our vocabulary!

We all work in a fluid market where technology evolves overnight, improving technical solutions.

Our competitive advantage is our passion for research and innovation, which is behind our outstanding projects and high-quality finished products, which bears the Xpozit signature!

We offer our clients a Commercial Department that ensures an ongoing relationship with the client and an effective organization of material processing strategies, assembly and after-sales assistance services.

Xpozit expresses innovative planning, customization of display solutions, high-quality materials and finishing in the tiniest detail.

Our passion!

Design

Our design team can offer you the most innovative projects.

Product development

We can create and adapt any display model to meet any customer requirements.

Survey

We can offer our customers complete information about stores all over Romania.

Production

Displays and ambient magnetic stalls

We offer our clients a complete range of solutions of product advertising:

- magnetic panels for ceramic and mosaic tiles
- magnetic displays for ceramic and mosaic tiles
- synoptic panels - both in the classic version and with magnetic system
- mobile panels
- floor displays
- exhibition shelves for ceramic tiles
- display systems of the pottery type
- stalls systems and magnetic ambience

Installation

We cover most of the countries in Central and Eastern Europe, including Romania.

Our commissioning teams and comprehensive logistics line ensure installation at any point described above.

Maintenance

We can cover any location in Central and Eastern Europe for maintenance.

In an emergency, we guarantee our presence for remedial works within 72 hours after the report.



15 years of experience

+10.000 Product displays

Product displays
Metal structure displays, laminated wood displays, shelves and customized systems.

220.000 mp Printed sticker

Our machines can realize different types of printing at maximum resolution, customized colour profiles, design and DTP preparation for your layouts.

1.600.000 kg Over 1600 tons of ceramic tiles

The average weight of ceramic tiles applied to panels within a single project and delivered to final customers.

300.000 km Average distance travelled by our teams.

We supply to most East-European countries. We have already installed in Romania, Hungary, Bulgaria, Serbia, Croatia, Greece, Bosnia, Montenegro, Macedonia and other countries.

+150 Our people

We have a team of designers, technical experts, workers and installation teams with experience and professionalism, able to execute our clients' projects to the most elevated criteria.

+75.000 Panels supplied and installed

The average number of panels enforced on sites



The Xpozit Magnetic Panel system is a patented invention protected by the patent cooperation pact.

About Xpozit

Xpozit is the business line of the BD Lemntech group of companies. Xpozit provides innovative showroom display solutions for the ceramics and flooring industry.

The company owns and operates its production capacities for wood and metal-based displays and also has well-trained commissioning teams, which performs in 12 countries from southeast Europe and Romania as a head office.

We are proud of the experience achieved in recent years, with a complete range of latest-generation machinery for woodworking, with machines for processing metals, but also with the printing facilities “in

house”, operated by a trustworthy team of specialists.

Xpozit aims to be distinguishable from other players performing in the same industry. Because we deeply understand the sales process, we provide complete design solutions.

We use our knowledge and experience to create a perfect link between the client’s product and the showroom space, offering the chance for the client to have the best achievable visibility at the POS.

Our solution, Xpozit Magnetic Panel System, is a factual illustration of this. This one comes to substitute the standard synoptic panel and the presentation stands from the showroom.

In this sense, we present to you below our patents.

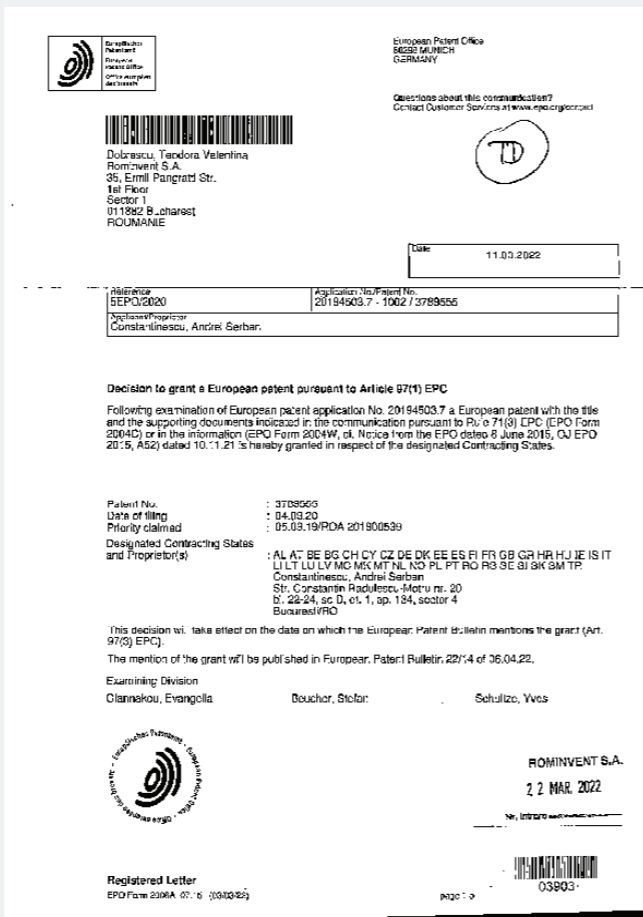

Let me introduce you Xpozit Magnetic Panel System!

The Xpozit Magnetic Panel System is a new type of display panel. This versatile system rethinks the whole POS ceramic display process.

The magnetic panel system replaces the traditional way of presenting ceramic tiles stuck on a display board, with a versatile magnetic panel that will never be replaced. Whenever a ceramic tile collection is updated, the magnetic panel remains in place, and only the tiles and ambient image are replaced.

Ceramic tiles and the ambient image are magnetically attached and, therefore, both can be easily changed when a new collection comes.

The system comes with many significant benefits in terms of speed of commissioning, minimal logistical

expenses for product exposition, the opportunity of replacing even a single plate in the panel, the minimal pressure for the POS during a new tiles collection replacement.

This system reduces the time from the ceramic factory to the POS presentation for new collections. We are discussing an ecological product, because the panel is no longer replaced at every update collection.

And last but not least – significant cost savings for the budget of the new stoneware collection.



PANELS



HAND PANELS





Magnetic panels
P-MAG

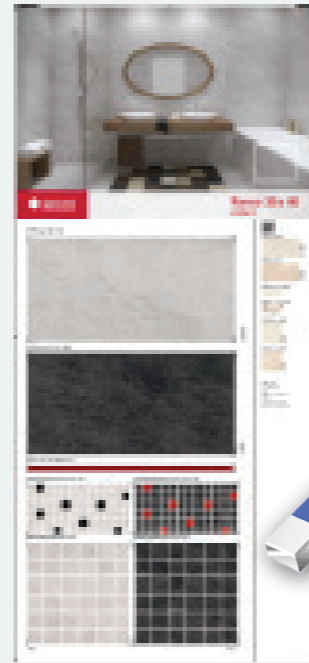

P-MPA
Raw PAL



P-MPB
melamine coated PAL



P-MPC
melamine coated PAL & digital print



P-MPD
melamine coated PAL + melamine print



**EXHIBITION
PANELS**

XR Series
XS Series
XF Series
XT Series

STRUCTURES



Metallic structures

XR-Compact Structures - 24+1

Metal Structure

XR-01



Height	Length	Depth	SIZE
2390mm	2330mm	1010mm	

PANEL type	
Raw PAL	✓
Melamine coated PAL	✓
Melamine coated PAL & digital print	✓
Melamine PAL & Print	✓

XR-Compact Structures M - 10+2 / 12+2

Metal Structure

XR-02



Height	Length	Depth	SIZE
3180mm	2215mm	1000mm	

LASTRE
3000x1000mm

XR-Compact Structures L - 10+2 / 12+2

Metal Structure

XR-03

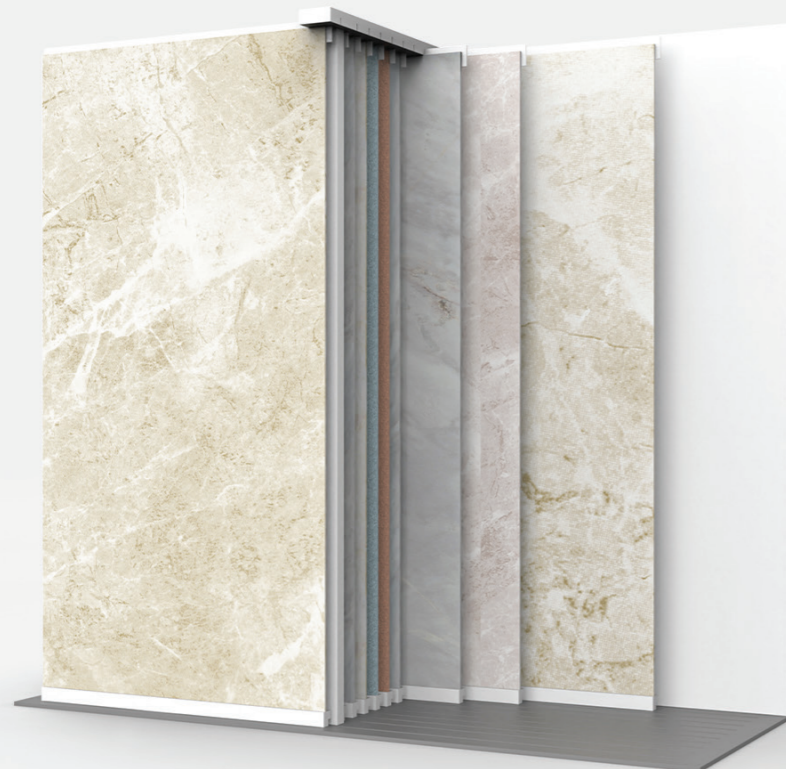

Height	Length	Depth	SIZE
2544mm	2630mm	1048mm	

LASTRE
2400x1200mm
2500x1250mm

XR-Compact Structures XL - 6+2

Metal Structure

XR-04



Height	Length	Depth	SIZE
3370mm	3200mm	900mm	

LASTRE
3200x1600mm

XR-Compact Structures T - 5+5
Metal Structure
XR-05



Boards

Height	Length	Depth
3385mm	3820mm	940mm

SIZE

XR-Compact Structures Basic 24A
Metal Structure
XR-06A



PANEL
1850x700mm

Height	Length	Depth
2260mm	1850mm	800mm

SIZE

PANEL type	
Raw PAL	<input checked="" type="checkbox"/>
Melamine coated PAL	<input checked="" type="checkbox"/>
Melamine coated PAL & digital print	<input checked="" type="checkbox"/>
Melamine PAL & Print	<input checked="" type="checkbox"/>

XR-Compact Structures Basic 24B
Metal Structure
XR-06B



PANEL
1850x800mm

Height	Length	Depth
2260mm	1850mm	900mm

SIZE

XR-Compact Structures Basic 10
Metal Structure
XR-07



PANEL
1850x700mm

Height	Length	Depth
2260mm	1350mm	800mm

SIZE

PANEL type	
Raw PAL	<input checked="" type="checkbox"/>
Melamine coated PAL	<input checked="" type="checkbox"/>
Melamine coated PAL & digital print	<input checked="" type="checkbox"/>
Melamine PAL & Print	<input checked="" type="checkbox"/>

XR-Compact Structures HPanel40
Metal Structure
XR-08



PANEL
900x600mm

Height	Length	Depth
2150mm	1250mm	700mm
2150mm	1600mm	700mm

SIZE

PANEL type	
Raw PAL	<input checked="" type="checkbox"/>
Melamine coated PAL	<input checked="" type="checkbox"/>
Melamine coated PAL & digital print	<input checked="" type="checkbox"/>
Melamine PAL & Print	<input checked="" type="checkbox"/>

XS-Compact Structures Slide 14A
Metal Structure
XS-01



PANEL
2010x1010mm

3D			SIZE
Height	Length	Depth	
2180mm	2220mm	1000mm	

PANEL type	
Raw PAL	✓
Melamine coated PAL	✓
Melamine coated PAL & digital print	✓
Melamine PAL & Print	✓

XS-Compact Structures Slide 27A
Metal Structure
XS-03



PANEL
2010x1010mm

3D			SIZE
Height	Length	Depth	
2180mm	3350mm	1000mm	

PANEL type	
Raw PAL	✓
Melamine coated PAL	✓
Melamine coated PAL & digital print	✓
Melamine PAL & Print	✓

XS-Compact Structures Slide 14B
Metal Structure
XS-02



PANEL
2010x1010mm

3D			SIZE
Height	Length	Depth	
2610mm	2600mm	1000mm	

XS-Compact Structures Slide 27B
Metal Structure
XS-04



PANEL
2010x1010mm

3D			SIZE
Height	Length	Depth	
2600mm	3350mm	1000mm	

PANEL type	
Raw PAL	✓
Melamine coated PAL	✓
Melamine coated PAL & digital print	✓
Melamine PAL & Print	✓

XS-Compact Structures Slide
Metal Structure
XS-05



Height	Length	Depth
2830mm	650mm	1420mm
2530mm	650mm	1420mm

SIZE

Number of panels
5x2

Board dimensions
1200x2700mm
1200x2400mm

XS-Compact Structures Slide
Metal Structure
XS-06 B



Height	Length	Depth
1060mm	1230mm	320mm
1360mm	1430mm	510mm
960mm	1570mm	790mm
1060mm	1710mm	930mm

SIZE

Number of panels
10

Board dimensions
450x900mm
600x1200mm
800x800mm
900x900mm

XS-Compact Structures Slide
Metal Structure
XS-06 A



Height	Length	Depth
1060mm	1230mm	320mm
1360mm	1430mm	510mm
960mm	1570mm	790mm
1060mm	1710mm	930mm

SIZE

Number of panels
10

Board dimensions
450x900mm
600x1200mm
800x800mm
900x900mm

XS-Compact Structures Slide
Metal Structure
XS-06 C



Height	Length	Depth
1060mm	1230mm	320mm
1360mm	1430mm	510mm
960mm	1570mm	790mm
1060mm	1710mm	930mm

SIZE

Number of panels
10

Board dimensions
450x900mm
600x1200mm
800x800mm
900x900mm

XF-Compact Structures Flip-A

Metal Structure
60x120
XF-01



Number of panels
8x2

Board dimensions
600x600mm
750x750mm
800x800mm
900x900mm
1000x1000mm
1200x1200mm

XF-Compact Structures Flip-B

Metal Structure
XF-02



Height	Length	Depth
1370mm	680mm	1300mm
1370mm	800mm	1300mm
1370mm	1040mm	1300mm
1370mm	1280mm	1300mm

Number of panels
5x2
6x2
8x2
10x2

Board dimensions
1000x1000mm

XF-Compact Structures Flip-C

Metal Structure
XF-03

XT-Technical Structures-A

Metal Structure
XT-01



Height	Length	Depth
2400mm	1240mm	600mm

Number of panels
52

Board dimensions
600x600mm
300x600mm
300x300mm

XT-Technical Structures-B
Metal Structure
XT-02



Height	Length	Depth
60mm	900mm	1000mm
60mm	900mm	1000mm
60mm	475mm	800mm
540mm	500mm	1000mm
550mm	460mm	250mm

Number of panels
6
8
9

Board dimensions
1200x1200mm
475x800mm
690x1040mm

XT-Technical Structures-C
Metal Structure
XT-03



Height	Length	Depth
1750mm	400mm	350mm

Number of panels
25

Board dimensions
250x250mm

XT-Technical Structures-D
Metal Structure
XT-04

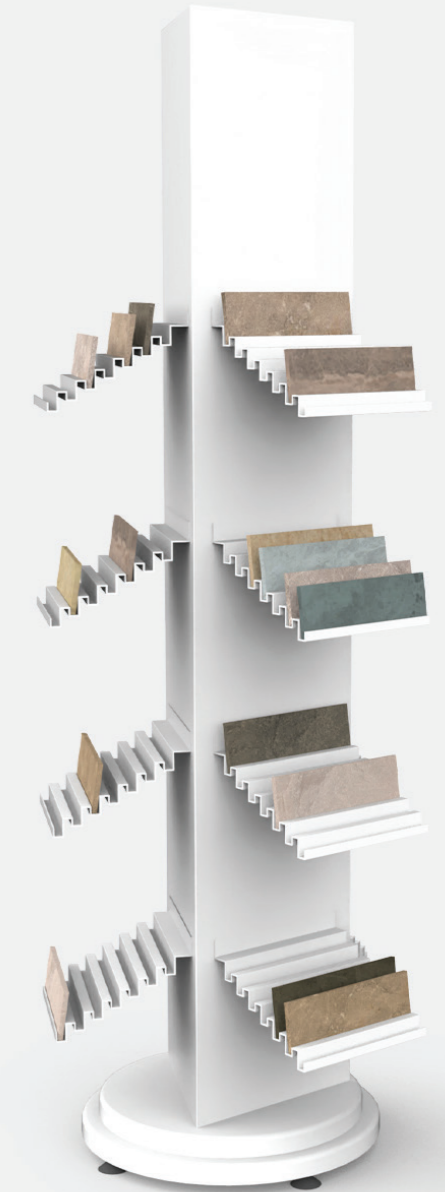

Height	Length	Depth
2180mm	600mm	600mm

Number of panels
84

CRADLES



Basic

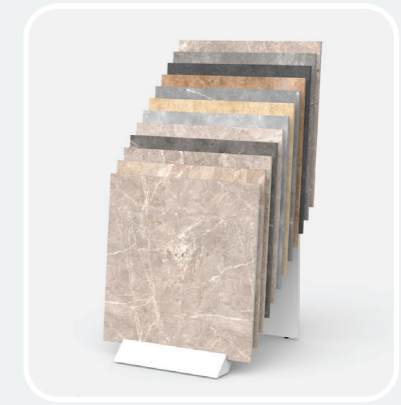

Monte



Busto



BackPrint

CRADLES
XC SERIES

Rugged

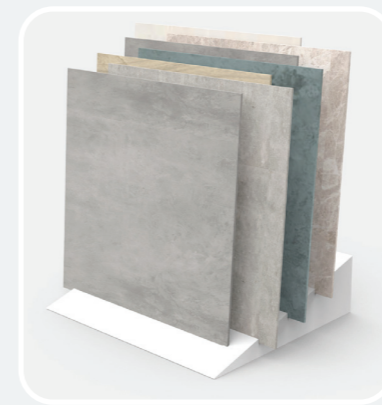

Mosaico

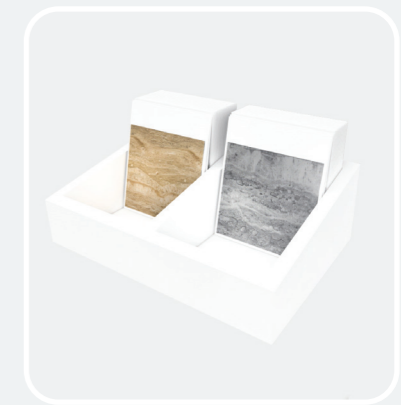

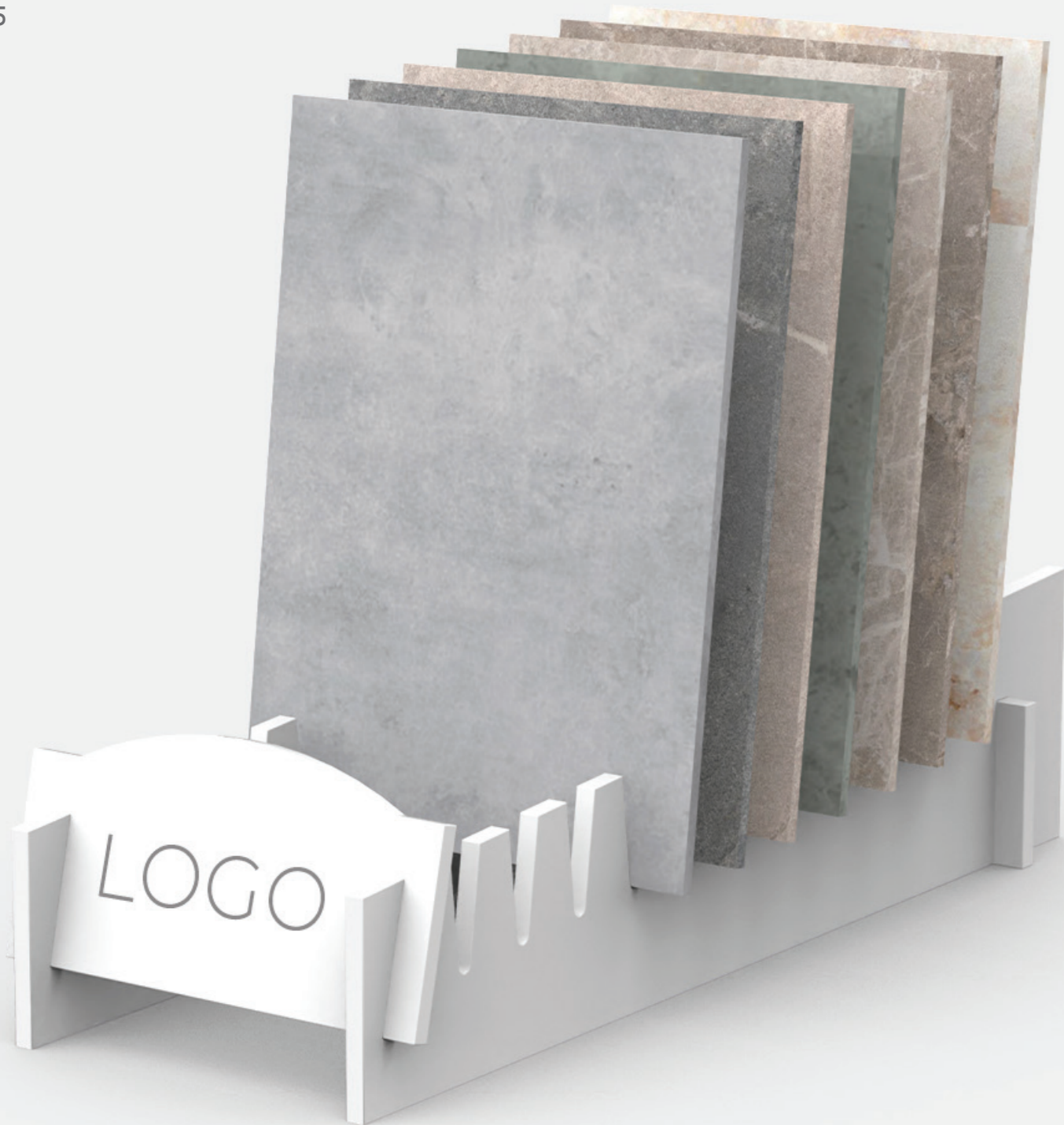

Height	Length	Depth	SIZE
260mm	410mm	1050mm	

Number of panels
10

Basic-01
MDF

Number of panels
10

Height	Length	Depth	SIZE
260mm	410mm	1050mm	

Basic-04
MDF

Number of panels
6

Height	Length	Depth	SIZE
510mm	360mm	520mm	

Basic-02
MDF

Number of panels
10

Height	Length	Depth	SIZE
480mm	440mm	500mm	

Basic-05
MDF

Number of panels
6

Height	Length	Depth	SIZE
350mm	400mm	650mm	

Basic-03
MDF

Number of panels
5

Height	Length	Depth	SIZE
730mm	550mm	500mm	

Basic-06
MDF

Number of panels
9

Height	Length	Depth	SIZE
1350mm	550mm	600mm	

Monte-01
MDF

Number of panels: 12

Board dimensions: 600x600mm

Height	Length	Depth
600mm	420mm	620mm

Monte-02
MDF

Number of panels: 9

Height	Length	Depth
250mm	500mm	270mm

Monte-03
MDF

Number of panels: 12

Board dimensions: 650x400mm

Height	Length	Depth
600mm	520mm	520mm

Monte-04
MDF

Number of panels: 6

Board dimensions: 680x980mm

Height	Length	Depth
280mm	1100mm	800mm

Busto-01
Metal

Number of panels: 7

Height	Length	Depth
230mm	250mm	620mm

BUSTO-02
Metal

Number of panels: 10

Height	Length	Depth
210mm	250mm	670mm

Busto-03
Metal

Number of panels: 29

Board dimensions: 1000X1000X20mm

Height	Length	Depth
850mm	2470mm	300mm

Busto-04
Metal

Number of panels: 12

Height	Length	Depth
240mm	250mm	650mm
230mm	200mm	650mm
240mm	450mm	650mm

Busto-05
Metal

Number of panels: 12

Height	Length	Depth
320mm	380mm	870mm

XC SERIES RUGGED

Rugged-01

MDF



Number of panels
12

Board dimensions
600x600mm

Height	Length	Depth
490mm	1200mm	440mm

Rugged-02

MDF

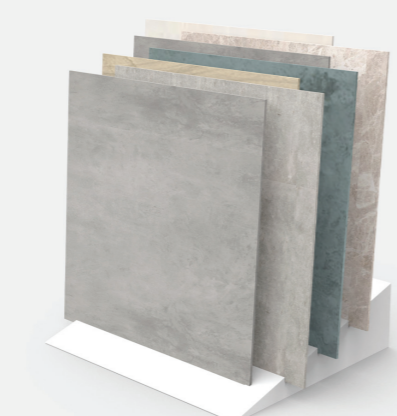

Number of panels
7

Board dimensions
1000x1000mm

Height	Length	Depth
260mm	1000mm	900mm

Rugged-07

MDF



Number of panels
6/8/9

Board dimensions
1200x1200mm
475x800mm
690x1040mm

Height	Length	Depth
60mm	900mm	1000mm
60mm	475mm	800mm
54mm	500mm	1000mm
55mm	460mm	250mm

Rugged-08

MDF



Number of panels
6/8/9

Board dimensions
1200x1200mm
475x800mm
690x1040mm

Height	Length	Depth
60mm	900mm	1000mm
60mm	475mm	800mm
54mm	500mm	1000mm
55mm	460mm	250mm

Rugged-03

MDF

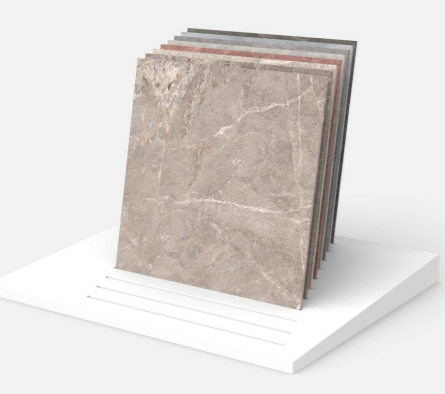

Number of panels
10

Board dimensions
750x750mm

Height	Length	Depth
980mm	1220mm	100mm
1620mm	880mm	800mm

Rugged-04

MDF



Number of panels
11

Height	Length	Depth
50mm	410mm	550mm

Rugged-09

MDF



Number of panels
14

Height	Length	Depth
85mm	600mm	800mm
140mm	500mm	795mm

Rugged-10

MDF



Number of panels
6

Height	Length	Depth
55mm	300mm	820mm

Rugged-05

MDF



Number of panels
6/8/9

Board dimensions
1200x1200mm
475x800mm
690x1040mm

Height	Length	Depth
60mm	900mm	1000mm
60mm	475mm	800mm
54mm	500mm	1000mm
55mm	460mm	250mm

Rugged-06

MDF



Number of panels
6/8/9

Board dimensions
1200x1200mm
475x800mm
690x1040mm

Height	Length	Depth
60mm	900mm	1000mm
60mm	475mm	800mm
54mm	500mm	1000mm
55mm	460mm	250mm

Rugged-11

MDF



Number of panels
7

Height	Length	Depth
35mm	300mm	600mm

Rugged-12

MDF



Number of panels
10

Height	Length	Depth
60mm	250mm	680mm

XC SERIES RUGGED

XC SERIES SOLO

Solo-01
MDF

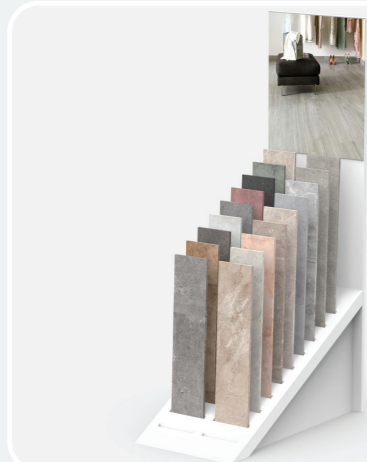

Number of panels: 12

Board dimensions: 180x500mm

Height	Length	Depth
960mm	400mm	590mm

SIZE

Solo-02
MDF



Number of panels: 10

Board dimensions: 150x900mm

Height	Length	Depth
1370mm	610mm	545mm

SIZE

Solo-03
MDF

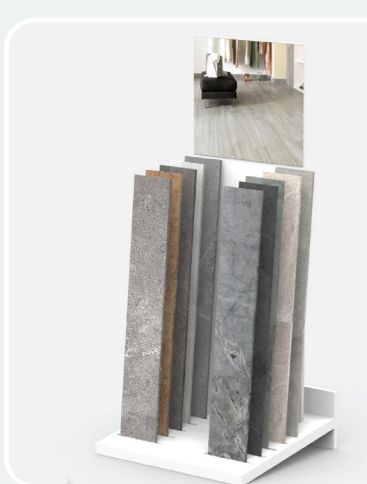

Number of panels: 6+6

Board dimensions: 150x900mm, 450x900mm

Height	Length	Depth
1600mm	480mm	570mm
1000mm	630mm	570mm

SIZE

Solo-04
MDF



Number of panels: 21

Board dimensions: 200x1200mm

Height	Length	Depth
900mm	550mm	1470mm

SIZE

Solo-05
MDF



Number of panels: 8+8

Board dimensions: 125x165mm

Height	Length	Depth
570mm	300mm	380mm

SIZE

Solo-06
MDF



Number of panels: 10+10

Height	Length	Depth
1540mm	450mm	870mm

SIZE

XC SERIES BACK PRINT

Back Print-01
MDF

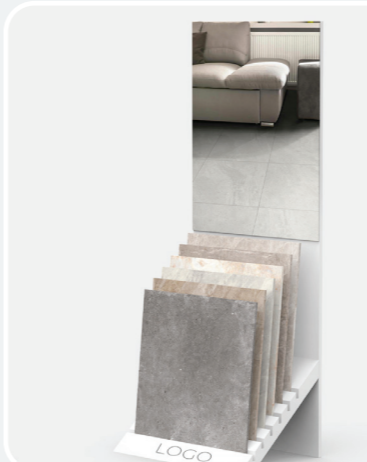

Number of panels: 6/10

Board dimensions: 600x1200mm

Height	Length	Depth
1700mm	680mm	480mm
2000mm	680mm	540mm
1600mm	680mm	640mm

SIZE

Back Print-02
MDF



Number of panels: 6

Height	Length	Depth
2100mm	680mm	680mm

SIZE

Back Print-03
MDF

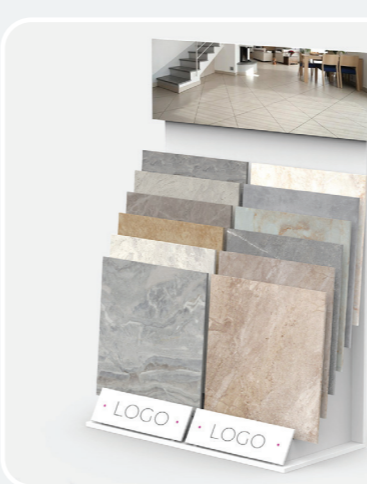

Number of panels: 12

Board dimensions: 600x600mm, 400x1200mm

Height	Length	Depth
1670mm	1230mm	520mm

SIZE

Back Print-04
MDF



Number of panels: 14

Height	Length	Depth
1810mm	660mm	990mm

SIZE

XC SERIES MOSAICO

Mosaico
MDF



Board dimensions: 500x500mm

Height	Length	Depth
120mm	240mm	165mm

SIZE

2.0 SERIES

Ceramic-01
Metal

Height	Length	Depth
1100mm	500mm	780mm

3D

SIZE



Ceramic-02
Metal



Number of panels
6/8/9

Board dimensions
1200x1200mm
475x800mm
690x1040mm

Height	Length	Depth
60mm	900mm	1000mm
60mm	475mm	800mm
54mm	500mm	1000mm
55mm	460mm	250mm

3D

SIZE

Ceramic-03
Metal

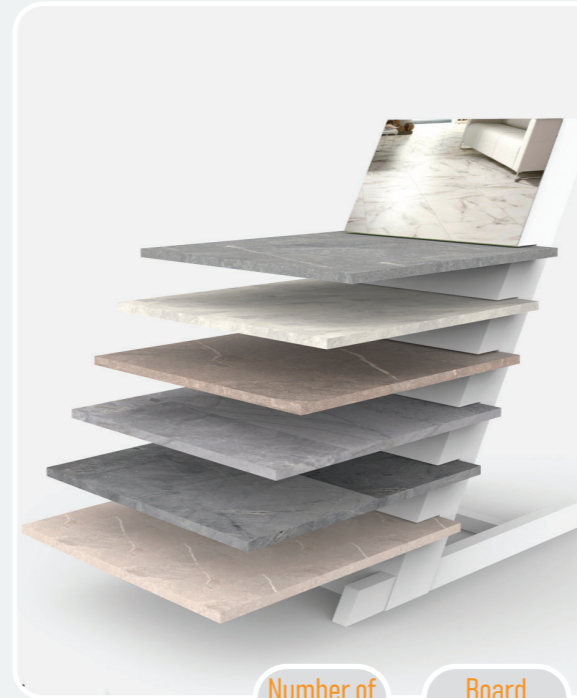

Number of panels
6/8/9

Board dimensions
1200x1200mm
475x800mm
690x1040mm

Ceramic-04
Metal



Number of panels
6/8/9

Board dimensions
1200x1200mm
475x800mm
690x1040mm

SANITARY

Sink-01
MDF



Customizable dimensions
2000x860x1320mm

BATHROOM
& KITCHEN

Sink-02
MDF

Customizable dimensions
1500x3190x800mm



Sink-03
MDF

Customizable dimensions
845x1500x600mm



Shower Panel
Metal



Customizable dimensions
2400x1020x1020mm

Dimensiuni PANEL
2130x900mm

Shower trays
MDF+Metal

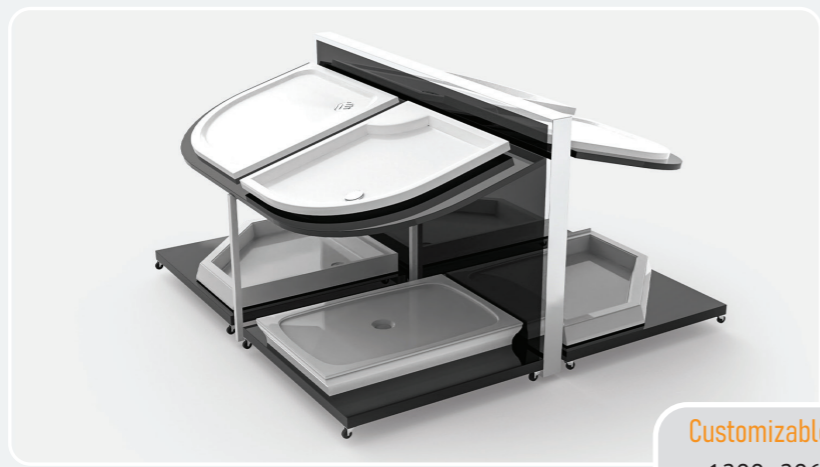

Customizable dimensions
1200x2060x2100mm

SHOWER
& TUB

Bath tubs
MDF

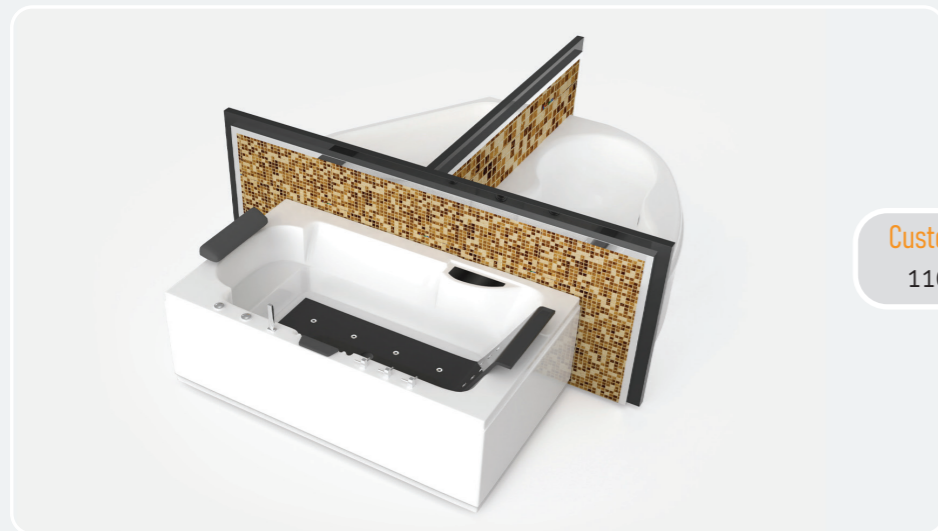

Customizable dimensions
1100x2140x2740mm

Accessory 01
MDF

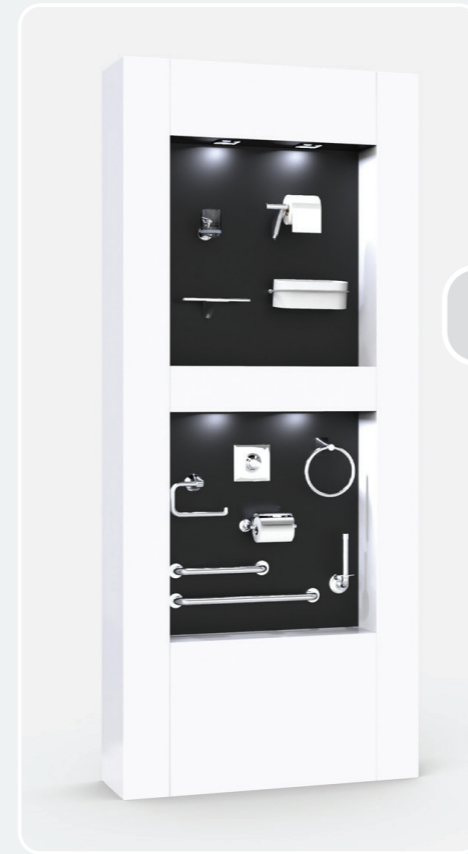

Customizable dimensions
2400x1000x360mm

Accessory 02
MDF



Customizable dimensions
2050x700x600mm

BATHROOM
ACCESSORIES

Accessory 03
MDF

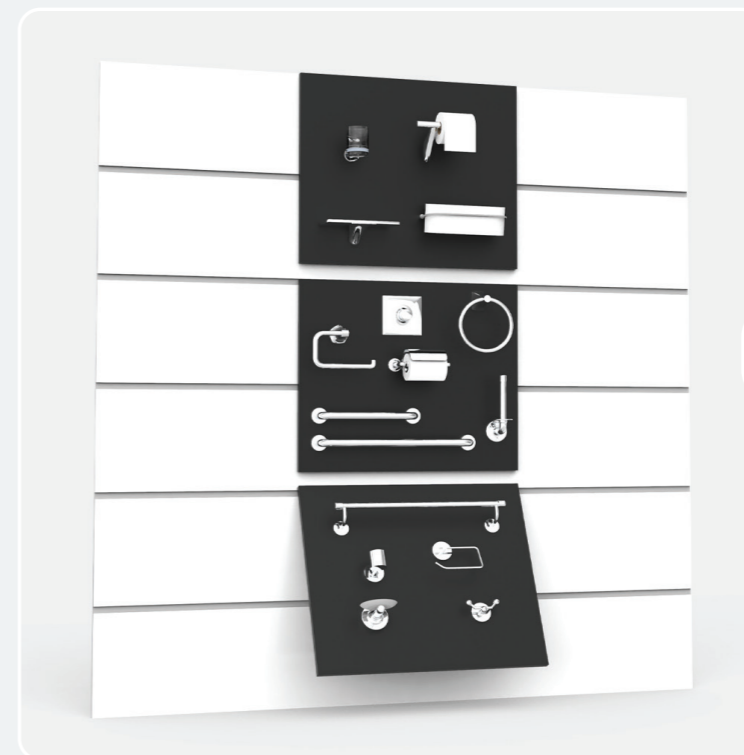

Customizable dimensions
670x700x242mm

Accessory 04
MDF+Metal



3D			SIZE
Height	Length	Depth	
2400mm	2500mm	1220mm	

Number of panels
3

Board dimensions
1200x2090mm

Accessory 05
MDF

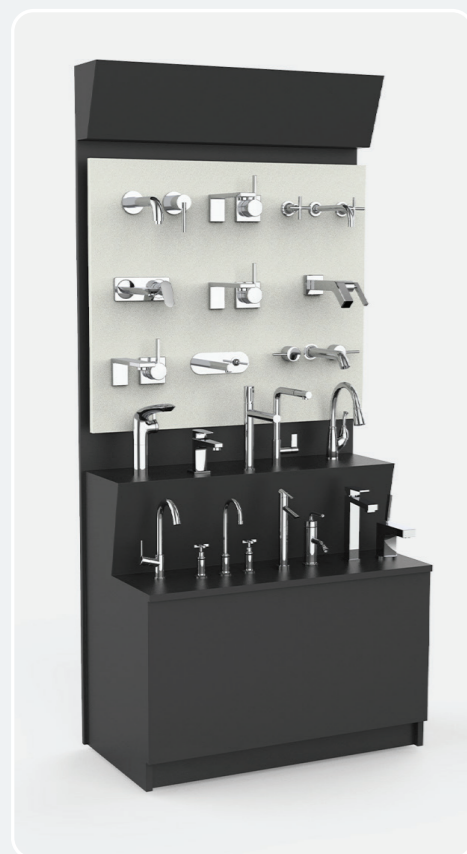

3D			SIZE
Height	Length	Depth	
1900mm	900mm	450mm	

Bathroom &
Kitchen
Accessories

Accessory 06
MDF



3D			SIZE
Height	Length	Depth	
2400mm	100mm	360mm	

PARQUET

Parquet 02

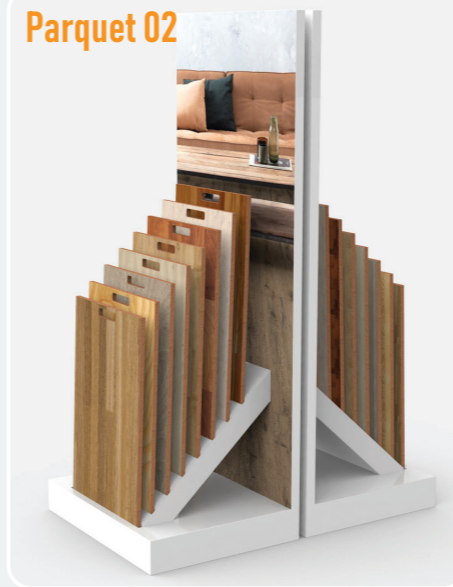

Parquet 03



Parquet 01

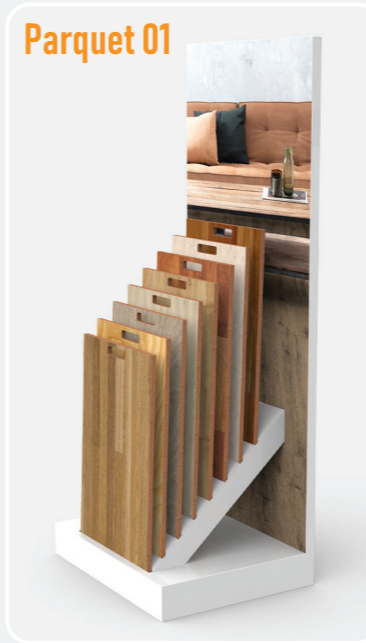

Smart
Display
PARCHT

Parquet 04



Parquet 06



Parquet 05



Valet 03



Parquet Shop

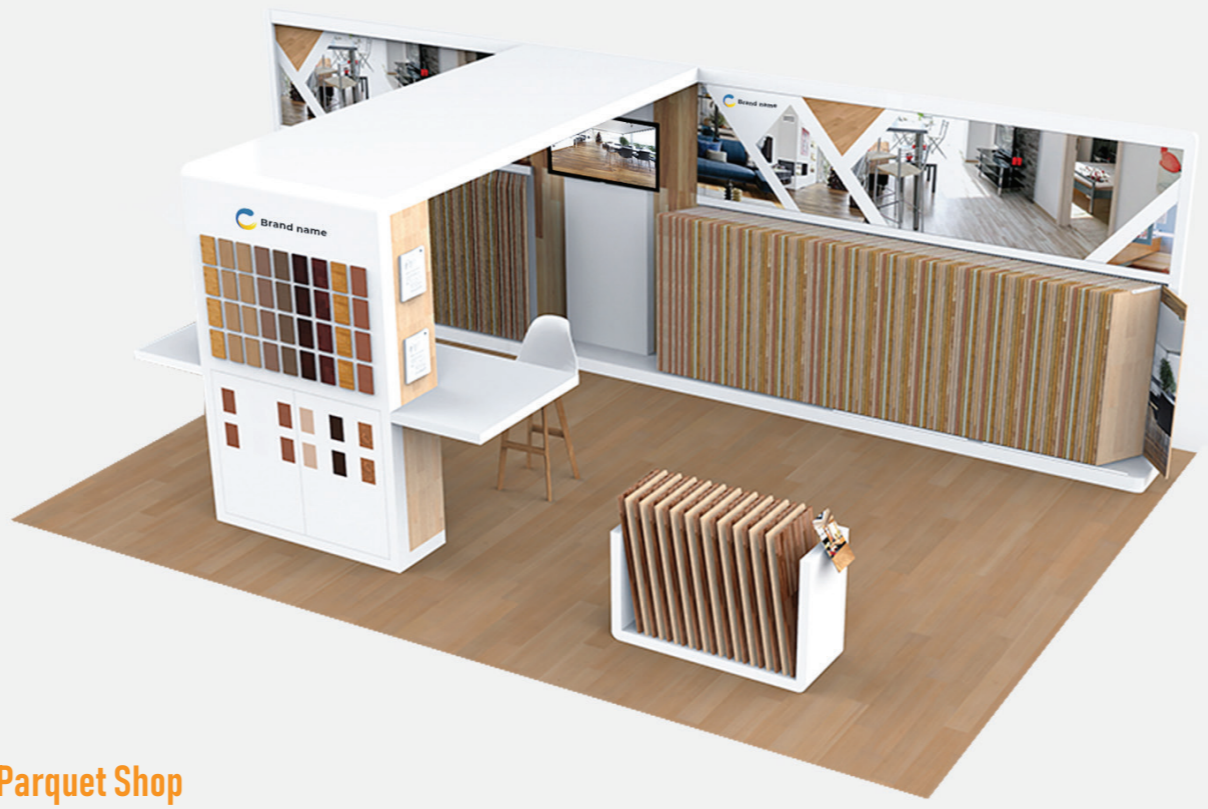

Valet 02



Stand 01



Stand 02



Valet 01



XV Series

PAIN

Modern Spray Stand

XV-01



Library Spray Stand

XV-03

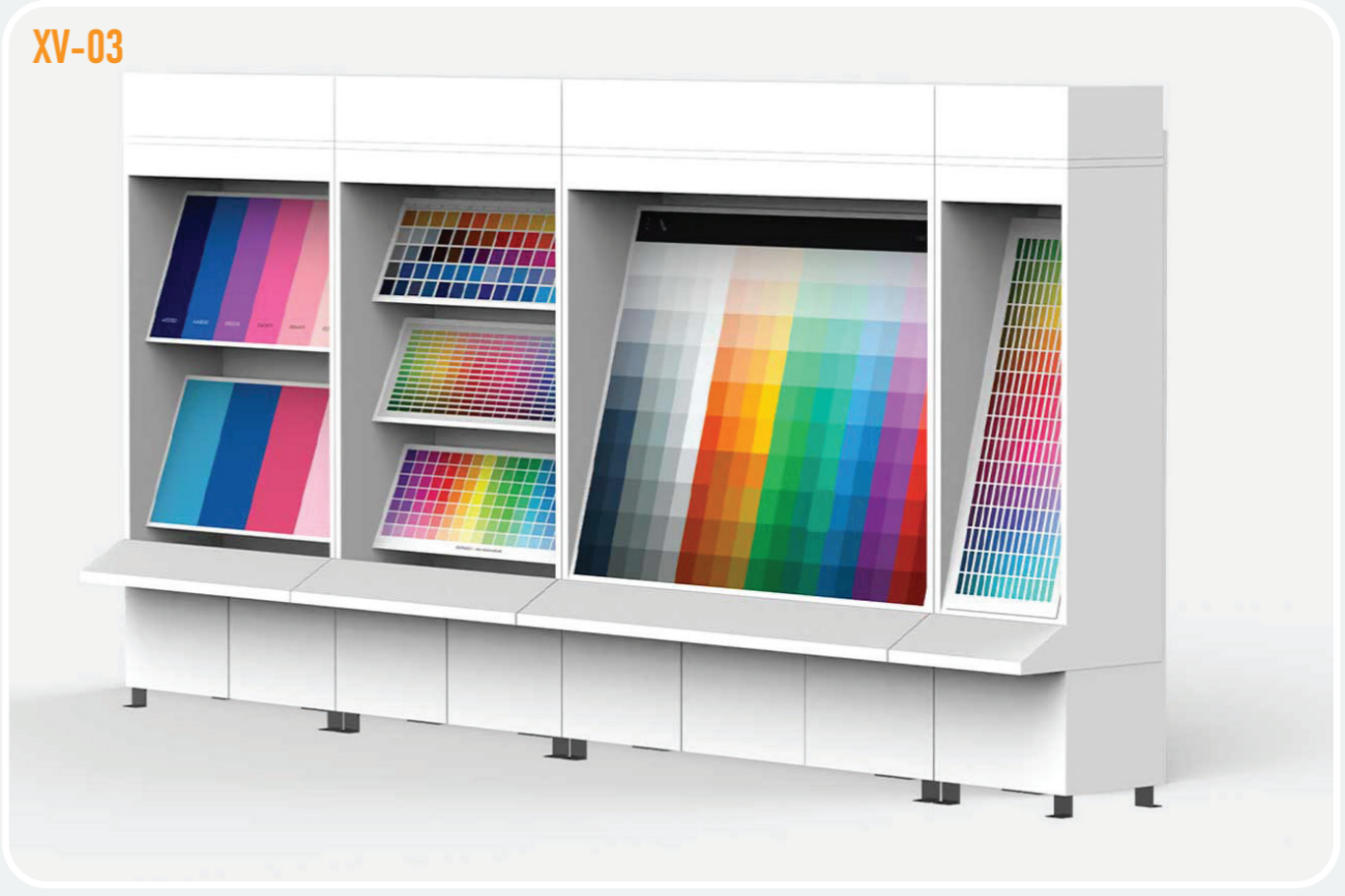

136 Spray Stand

XV-02A



Paint & Accesories

Minion Spray Stand

XV-02B



Brush Spray Stand

XV-04



COOLING & HEATING



XCH-01



XCH-01-3



XCH-01-4



XCH-02A

COOLING & HEATING

BRAND NAME



XCH-06



XCH-03A

XCH-04



BRAND NAME



XCH-02

BRAND NAME



XCH-03

XCH-05





XCH-12



XCH-13



XCH-14



XCH-15

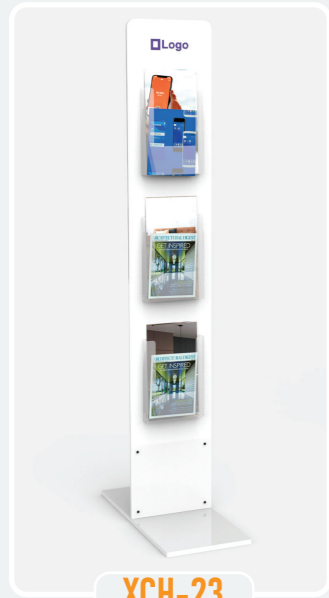

XCH-23

MIX DISPLAYS

COOLING & HEATING



XCH-16



XCH-22

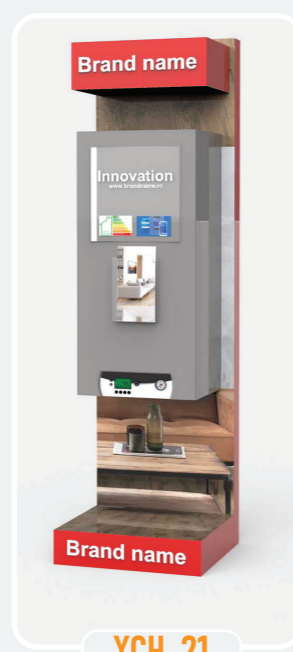

XCH-21



XCH-20



XCH-19

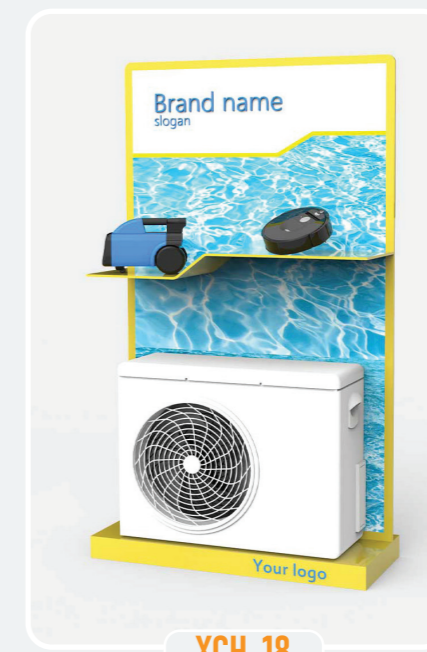

XCH-18



XCH-17

ELECTRIC



XEL-01



XEL-02



Presentation Display

XEL-03



XEL-06

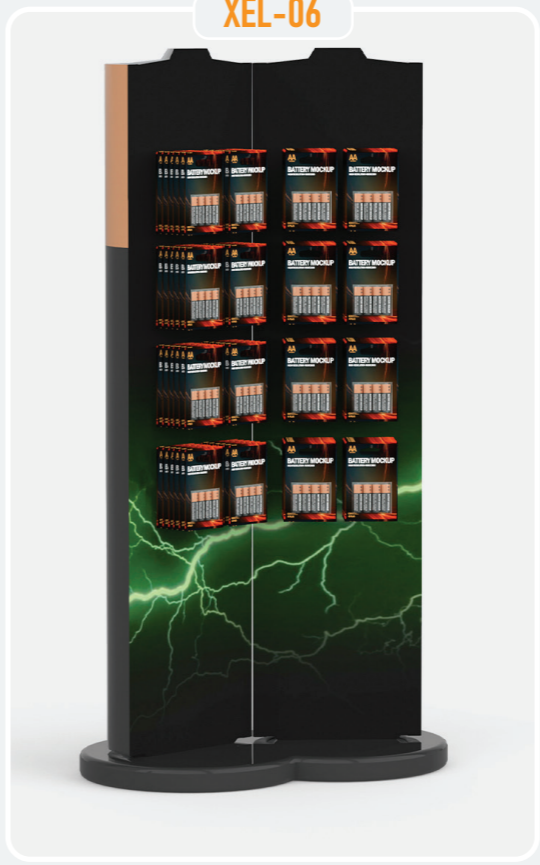

XEL-07

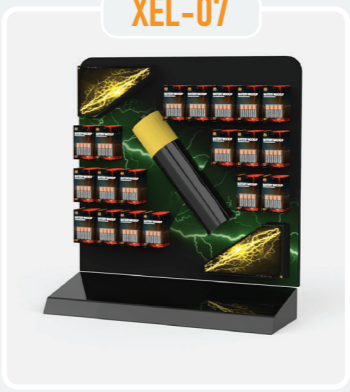

Batteries Displays

XEL-08

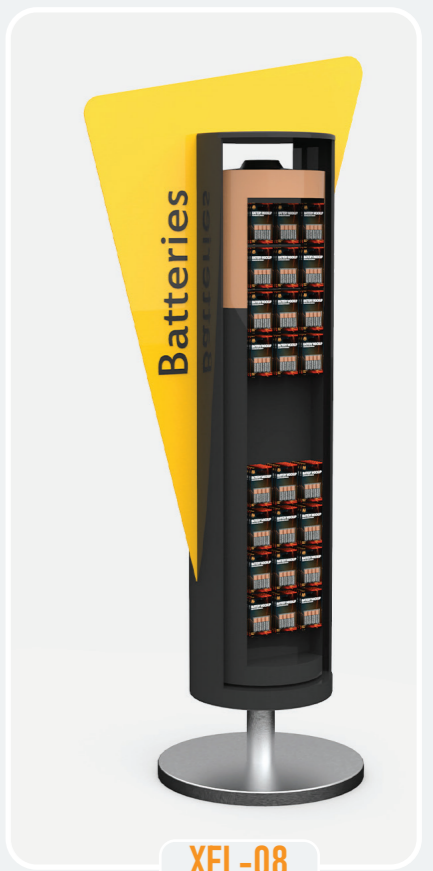

XEL-04



Accessories Displays

XEL-05

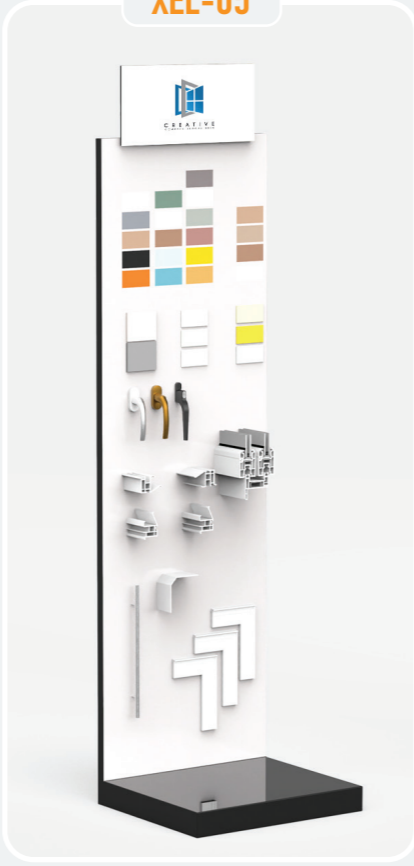

XEL-09

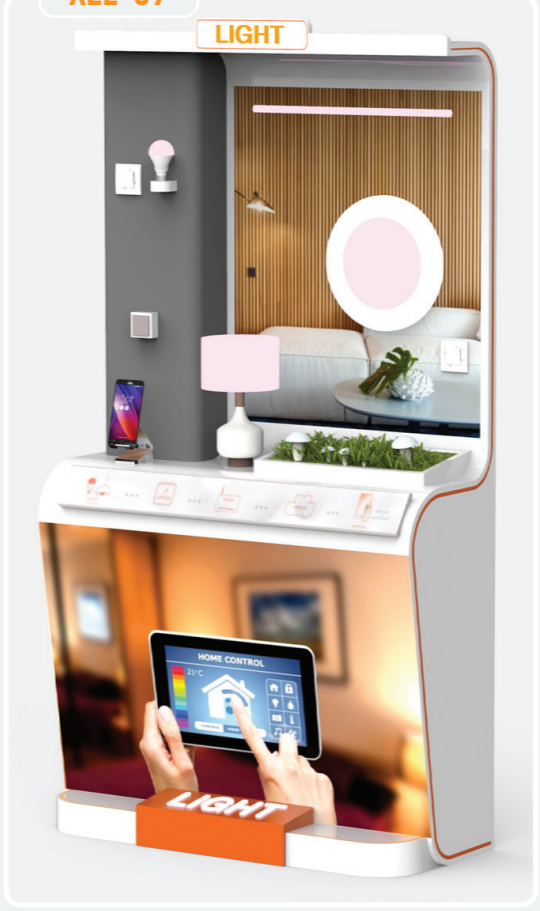

Phones & Tablets Displays

XEL-10



XEL-11

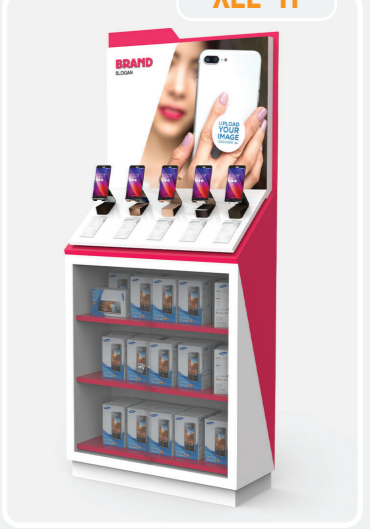

XEL-12



XEL-13



XEL-14



XEL-15



Lighting Products Displays

XEL-16

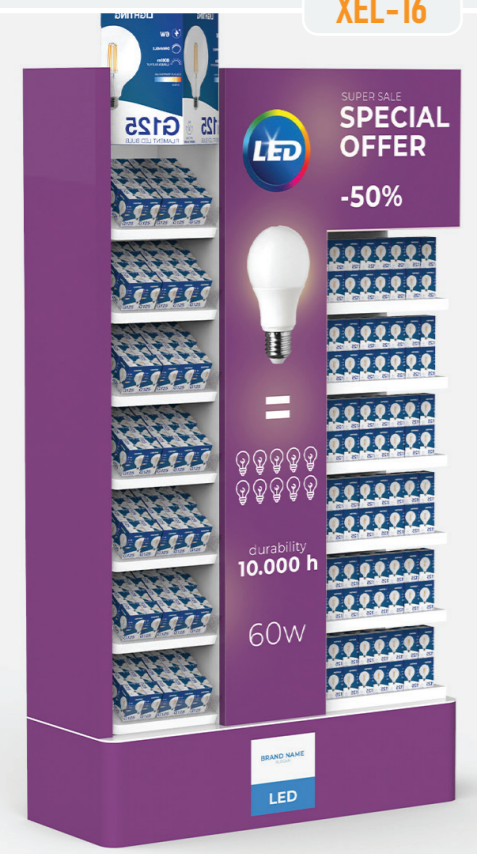

XEL-17



XEL-18



XEL-19



XUA Series - Tools
XMA Series - Mastics and Adhesives

TOOLS



TOOLS & EQUIPMENT DISPLAYS

XUA-01



XUA-02



XUA-03



XUA-04

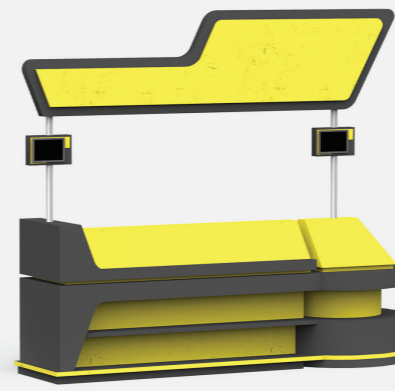

XUA-05



XUA-06



XUA-12



XUA-11



XUA-10



XUA-09



XUA-08



XUA-07



XMA-01



XMA-02



XMA-03



XMA-04



MASTIC /
ADHESIVES / FOAM
DISPLAYS

XMA-09



XMA-08



XMA-07



XMA-06



XMA-05



MAGNETIC AMBIENCE

The new Magnetic Ambience

Almost every showroom has one or more presentation stalls. This is where the merchants can display and combine the ceramic tiles with sanitary items and create an example of a mini-environment.

We used the innovative magnetic panel system for such a presentation stall. Now we have a complete kit, and creating a mini-environment is easier than at any time. Anyone can ensemble it in a short time, without the mess. And with this innovative kit, our customers can change the ceramic tiles as often as they want with minimal effort.



The magnetic kit contains

1. Ultralight magnetic panels

- The magnetic system is also applied in environments, the light panels being the most convenient solution for obtaining the maximum advantage in a short time, effortless

2. U-type closing profiles

- The panels are fixed with aluminium profiles

3. Magnet for ceramic tiles

- Adapted to any board size

4. Special fittings for sanitary items and furniture

- The metal elements are designed for fixing any product - from cabinets and mirrors to toilet bowls and sinks



Models of "magnetic ambience" for the showroom
They can be executed in any other combination



THE SYSTEM OF MAGNETIC AMBIENCE APPLICATION TO TILES, FURNITURE AND SANITARY OBJECTS



1 Build the frame of the Magnetic Ambience using profiles from the magnetic kit.

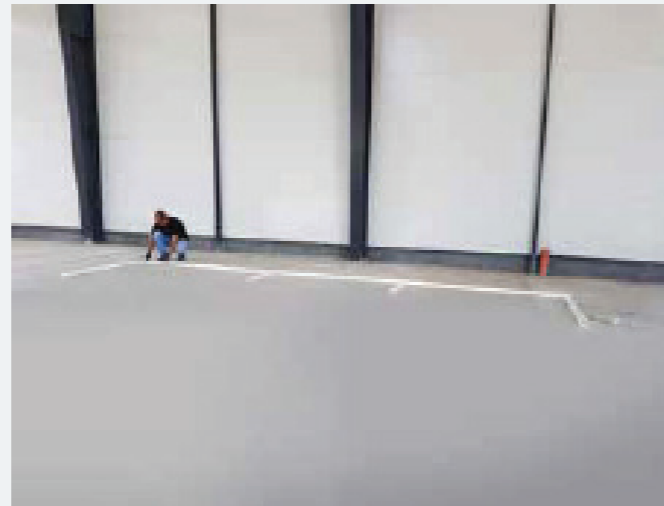

2 The kit will be assembled according to the footprint of your stall. The system is modular and can be reconfigured at any time.



3 The panels slide into the base profiles. No technical experience is necessary for the installation of the magnetic system

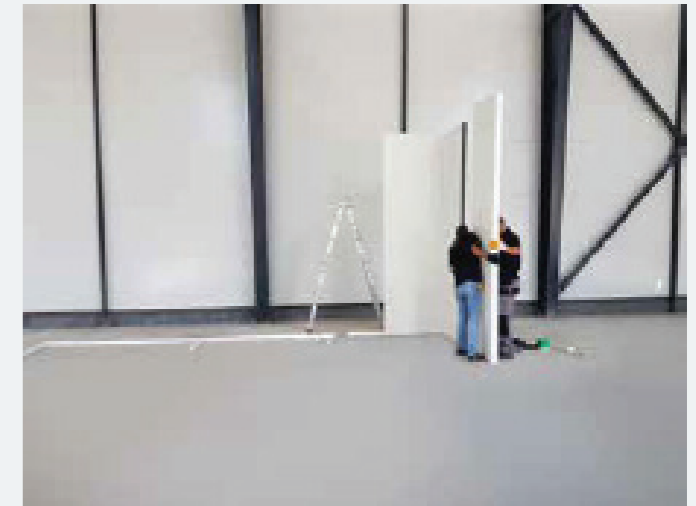

4 The panels are installed in the base frame using the interlock-type fixing system.

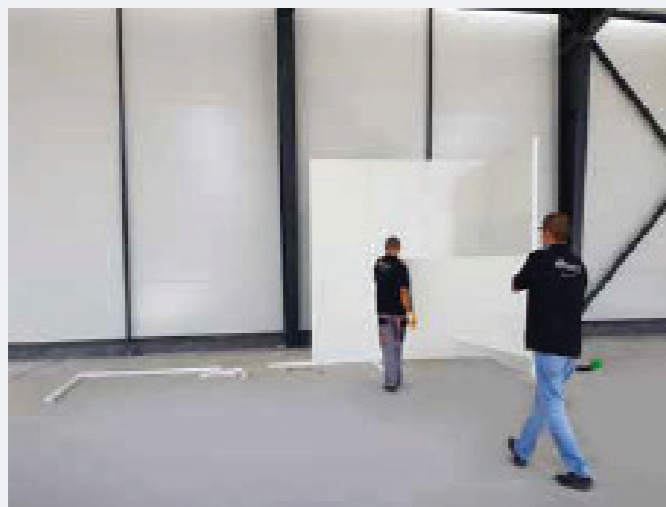

5 Installation can be done with only 2 people. Because the panels are ultralight and we don't have to involve special transport equipment.



6 The final image of the magnetic ambience

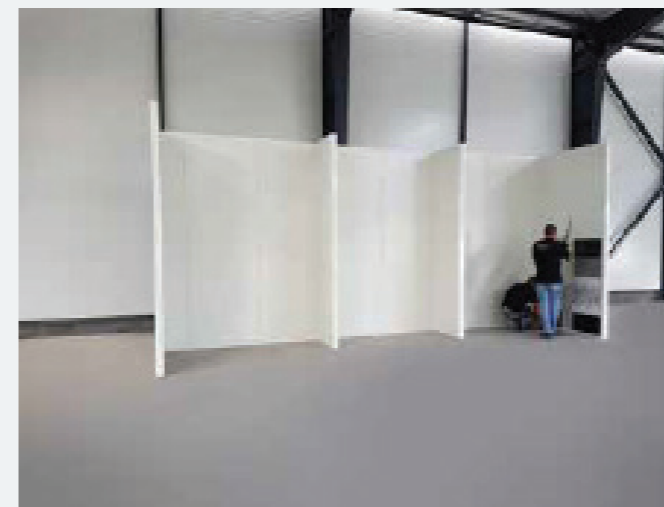

7 After assembling the panels, the team starts applying the ceramic tiles



8 The application is made in a short time, and the result is easily seen

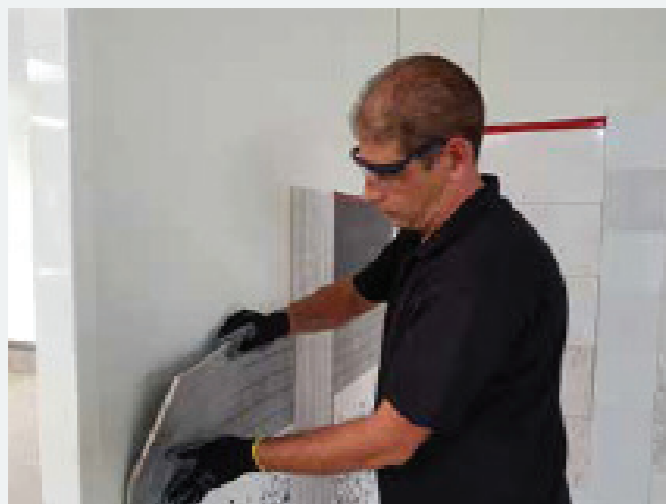

9 The last plates are applied - the system works with all formats. In the picture, the worker installs mosaic tiles.

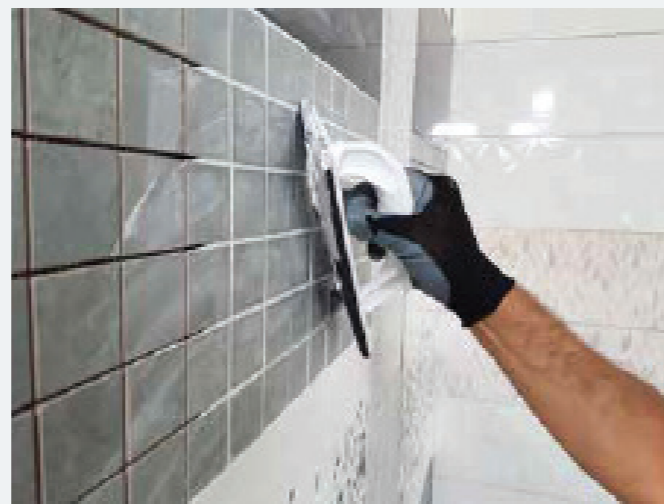

10 After installing all the boards, you can apply the joint putty. The system allows the application and removal of joint putty without traces or dirt.

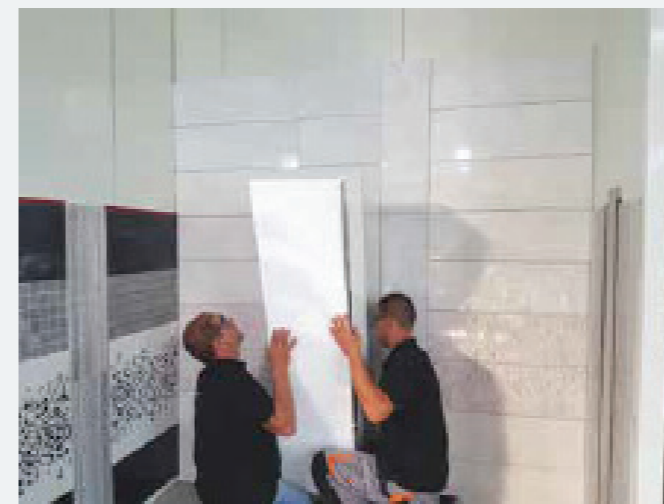

11 The furniture can be installed using the magnetic system.

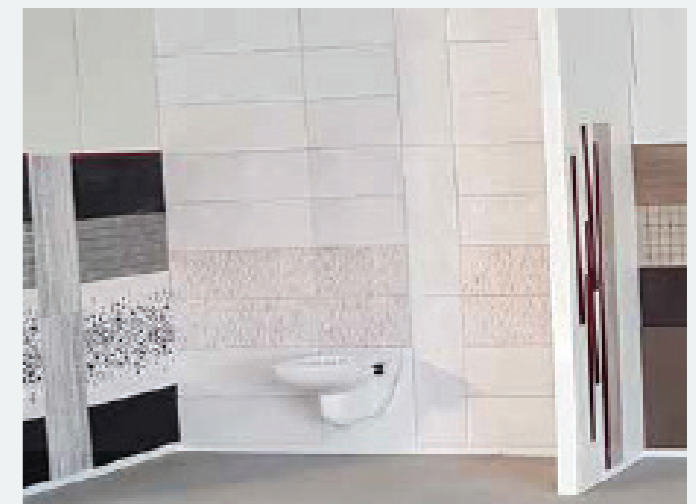

12 Sanitary objects can be applied easily.



This is the new Magnetic Ambience System.
It optimizes the space and exhibits effectively.
It innovates and brings a new image.



MAGNETIC
AMBIENCE



Stall system
with Magnetic
Ambience for
DIY stores



DIY MAGNETIC SYSTEMS

DIY stores

The magnetic panel system also proves its usefulness for type shops DIY, where it can be used mainly in tile sales.

The magnetic panels can be applied instead of the display panels on the systems cantilever without changing the existing structure of the shelves.

In this way, the modification and combination of collections on these panels can be done quickly and without additional effort on the part of the store.

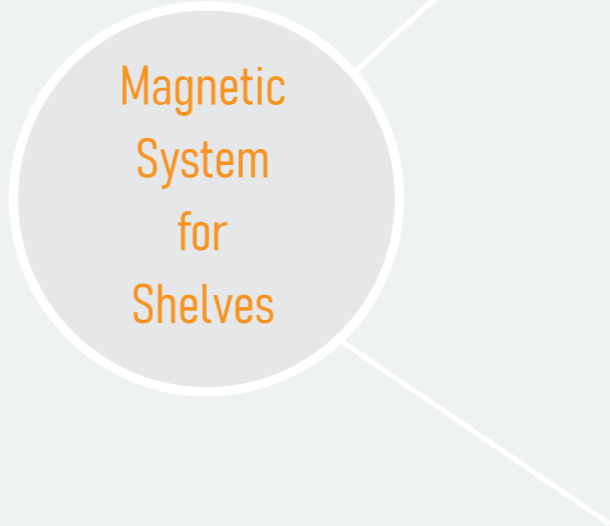
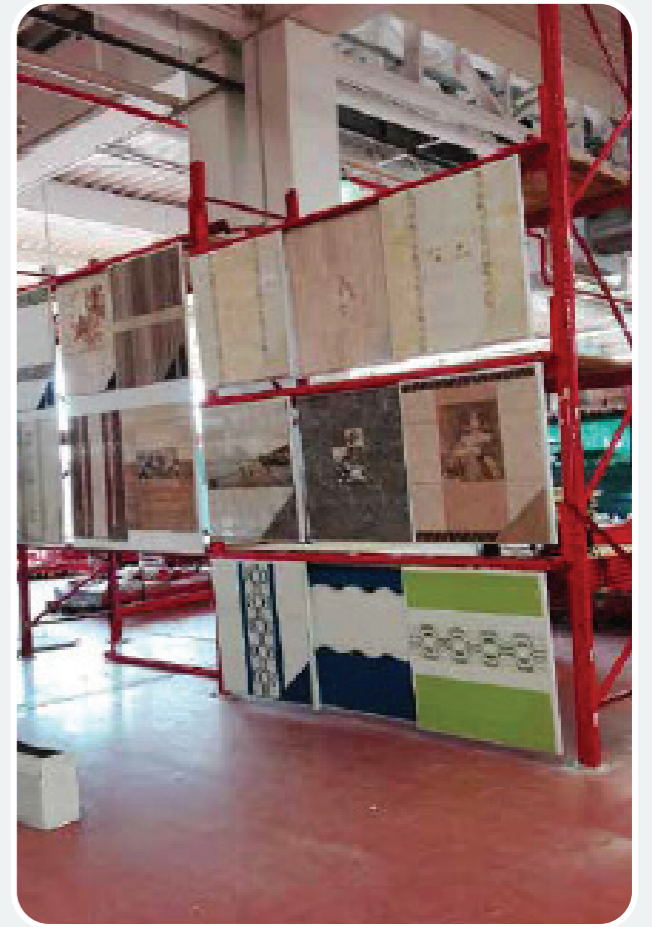

The magnetic panels can be made in any size to fit the allocated space. They can be mounted on the existing roller system. The lightweight magnetic panel system has been tested and is guaranteed to withstand shocks, sudden movements or blows.

Store employees can easily do the replacement of ceramic tiles without additional tools.

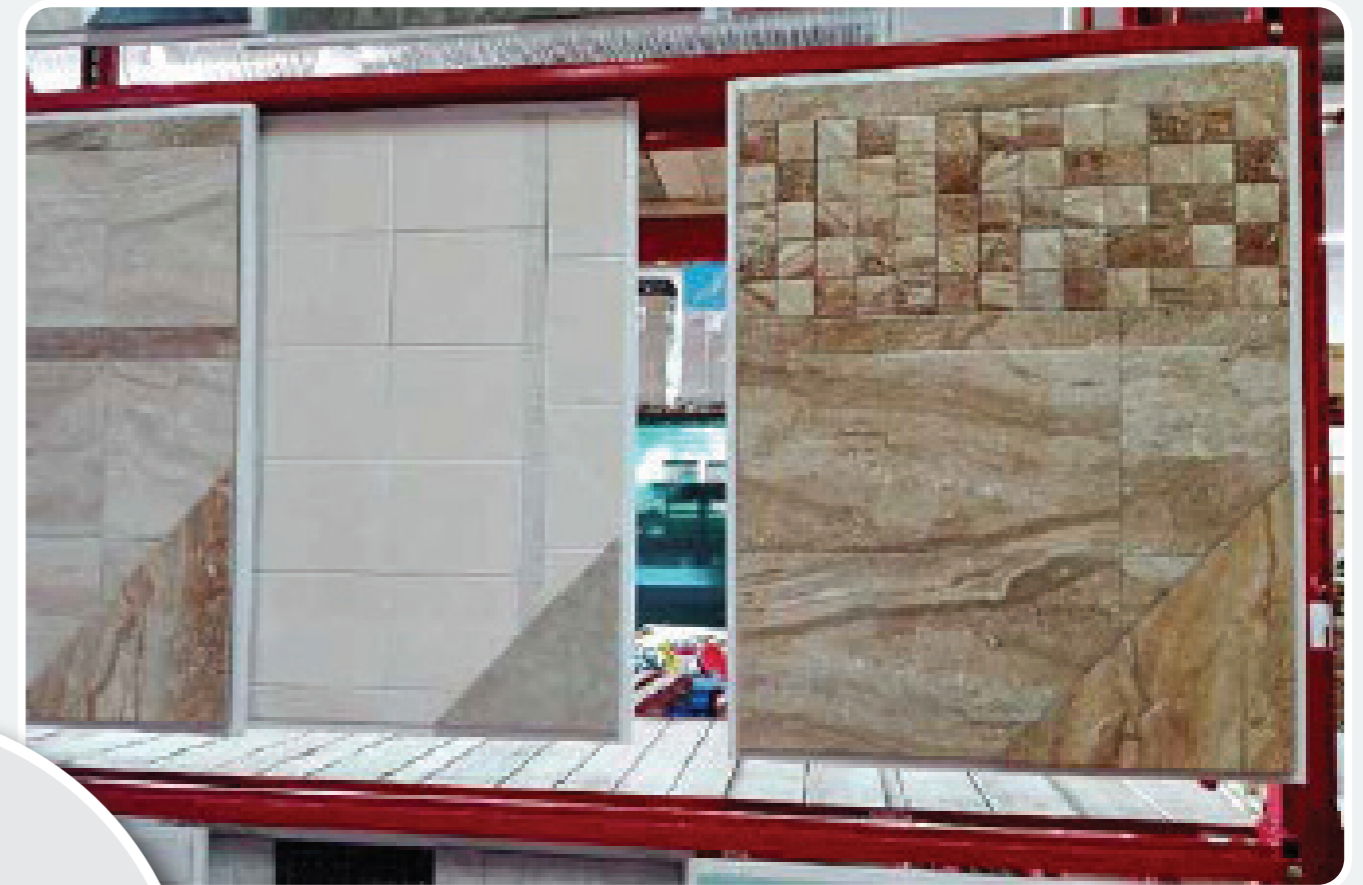

Magnetic panels for shelves can be made in any other size



Comprehensive services for your company!

We deliver the most suitable solution for displaying ceramic products - the Magnetic Panel System. That is why our SERVICES guarantee that we are trustworthy partners.



DESIGN

We continuously think of new presentation paths and functional systems that combine aesthetic appeal, ergonomics, cost and durability.



PRODUCTION PLANNING

We work with our customers to design projects that faultlessly suit each store's needs and are delivered to the market in the quickest possible time.



SERIES PRODUCTION

We carefully observe all production phases, from raw materials to the final product. We do not have a minimum order quantity. For us, every customer is important.



DELIVERY AND INSTALLATION

Easy to install and operate, our patented methods are enforced throughout Romania and Central and Eastern Europe.

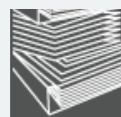

ANALYZE

We pick the most suitable materials, use high-performance equipment, mix fashion with technology and offer a product that reflects innovation and functionality at the highest benchmarks.



MAINTENANCE

Our professionals assure rapid intervention in less than 72 hours in any store from Central and Eastern Europe, Romania included. We know the quality of our work and guarantee the quality of our products.



SURVEY

We can provide our clients complete information about any store from our area of interest - starting from the number of manufacturers in the POS, the total size for display and the logistics unrestricted in that store. And, finally, contacts!

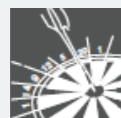

RESULT

As a result, we provide a perfect partnership which can fulfil all the requirements of exposure and communication at the last point of sale.

XPOZIT

TECHNICAL PLANS



XS-05

Height	Length	Depth
2830mm	650mm	1420mm
2530mm	650mm	1420mm

Number of panels
5x2

Board dimensions
1200x2700mm
1200x2400mm

XS-06 A / XS-06 B / XS-06 C / XS-06 D

Height	Length	Depth
1060mm	1230mm	320mm
1360mm	1430mm	510mm
960mm	1570mm	790mm
1060mm	1710mm	930mm

Number of panels
10

Board dimensions
450x900mm
600x1200mm
800x800mm
900x900mm

XT-01

Height	Length	Depth
2400mm	1240mm	600mm

Number of panels
52

Board dimensions
600x600mm
300x600mm
300x300mm

XT-02

Height	Length	Depth
60mm	900mm	1000mm
60mm	900mm	1000mm
60mm	475mm	800mm
540mm	500mm	1000mm
550mm	460mm	250mm

Number of panels
6
8
9

Board dimensions
1200x1200mm
475x800mm
690x1040mm

XF-01

Number of panels
8x2

Board dimensions
600x600mm
750x750mm
800x800mm
900x900mm
1000x1000mm
1200x1200mm

XF-02 / XF-03

Number of panels
5x2
6x2
8x2
10x2

Board dimensions
1000x1000mm

Height	Length	Depth
1370mm	680mm	1300mm
1370mm	800mm	1300mm
1370mm	1040mm	1300mm
1370mm	1280mm	1300mm

XT-04

Height	Length	Depth
2180mm	600mm	600mm

Number of panels
84

CRADLES

Basic-01

Height	Length	Depth
260mm	410mm	1050mm

Number of panels: 10

Basic-02

Height	Length	Depth
480mm	440mm	500mm

Number of panels: 10

Basic-05

Height	Length	Depth
350mm	400mm	650mm

Number of panels: 6

Basic-06

Height	Length	Depth
1350mm	550mm	600mm

Number of panels: 9

Basic-03

Height	Length	Depth
730mm	550mm	500mm

Number of panels: 5

Basic-04

Height	Length	Depth
510mm	360mm	520mm

Number of panels: 6

Monte-01

Height	Length	Depth
600mm	420mm	620mm

Number of panels: 12

Board dimensions: 600x600mm

Monte-02

Height	Length	Depth
250mm	500mm	270mm

Number of panels: 9

CRADLES

Monte-03

Height	Length	Depth
600mm	520mm	520mm

Number of panels: 12

Board dimensions: 650x400mm

Monte-04

Height	Length	Depth
280mm	1100mm	800mm

Number of panels: 6

Board dimensions: 680x980mm

Busto-03

Height	Length	Depth
850mm	2470mm	300mm

Number of panels: 29

Board dimensions: 1000x1000x20mm

Busto-01

Height	Length	Depth
230mm	250mm	620mm

Number of panels: 7

Busto-02

Height	Length	Depth
210mm	250mm	670mm

Number of panels: 10

Busto-04

Height	Length	Depth
240mm	250mm	650mm
230mm	200mm	650mm
240mm	450mm	650mm

Number of panels: 12

Busto-05

Height	Length	Depth
320mm	380mm	870mm

Number of panels: 12

CRADLES

Rugged-01

Height	Length	Depth
490mm	1200mm	440mm

Number of panels: 12

Board dimensions: 600x600mm

Rugged-02

Height	Length	Depth
260mm	1000mm	900mm

Number of panels: 7

Board dimensions: 1000x1000mm

Rugged-05 / 06 / 07 / 08

Height	Length	Depth
60mm	900mm	1000mm
60mm	475mm	800mm
54mm	500mm	1000mm
55mm	460mm	250mm

Number of panels: 6, 8, 9

Board dimensions: 1200x1200mm, 475x800mm, 690x1040mm

Rugged-09

Height	Length	Depth
85mm	600mm	800mm
140mm	500mm	795mm

Number of panels: 14

Rugged-03

Height	Length	Depth
980mm	1220mm	100mm
1620mm	880mm	800mm

Number of panels: 10

Board dimensions: 750x750mm

Rugged-04

Height	Length	Depth
50mm	410mm	550mm

Number of panels: 11

Rugged-10

Height	Length	Depth
55mm	300mm	820mm

Number of panels: 6

Rugged-11

Height	Length	Depth
35mm	300mm	600mm

Number of panels: 7

CRADLES

Rugged-12

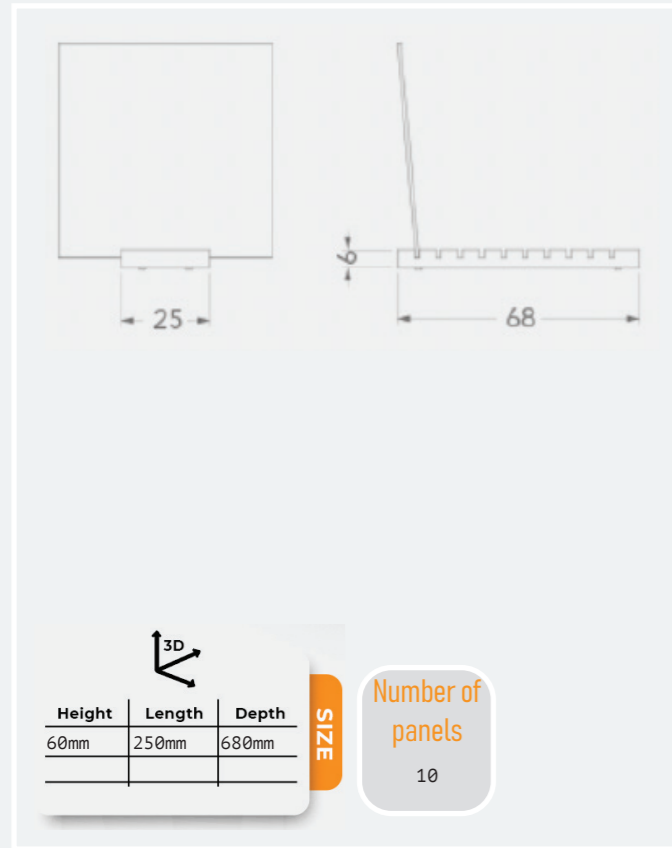

Solo-01

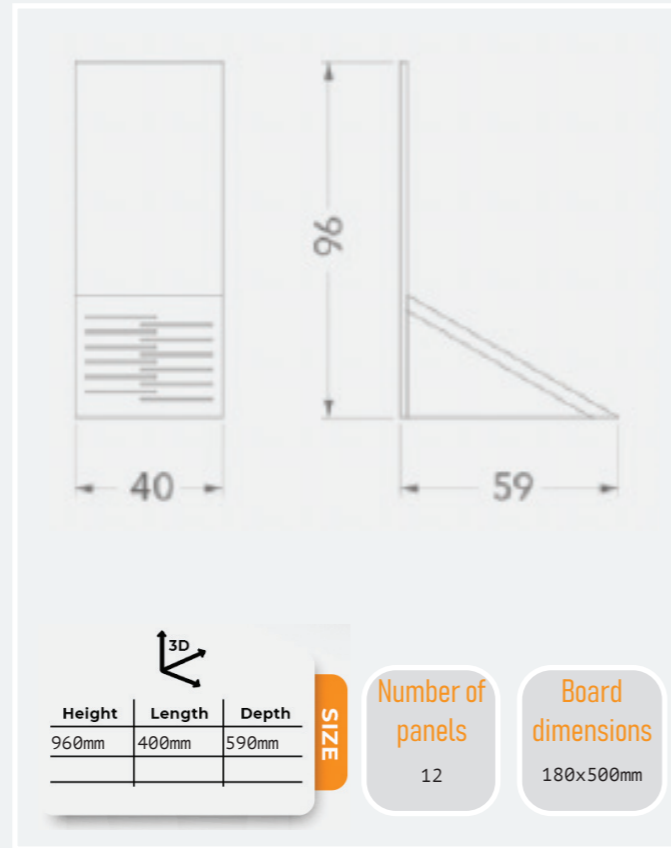

Solo-05

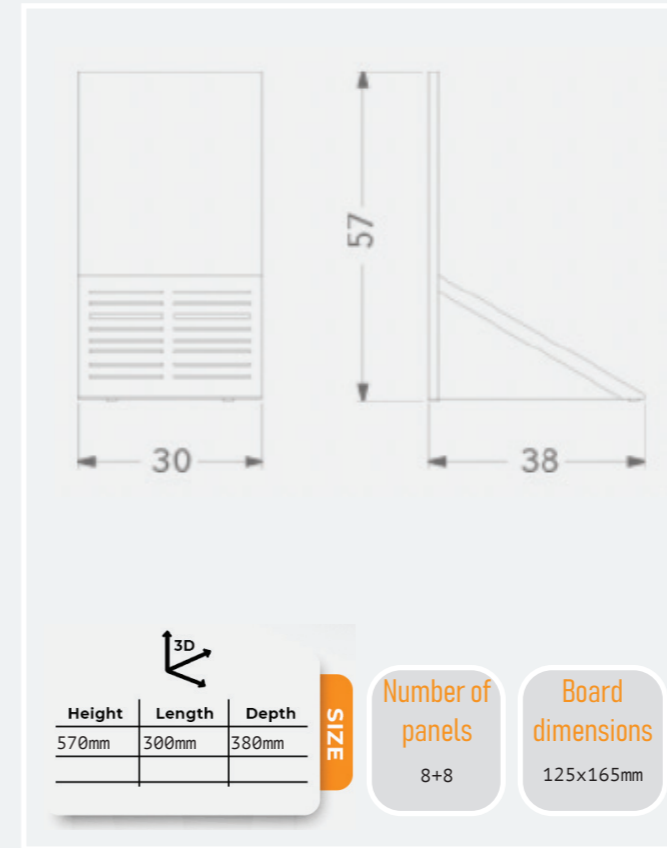

Solo-06

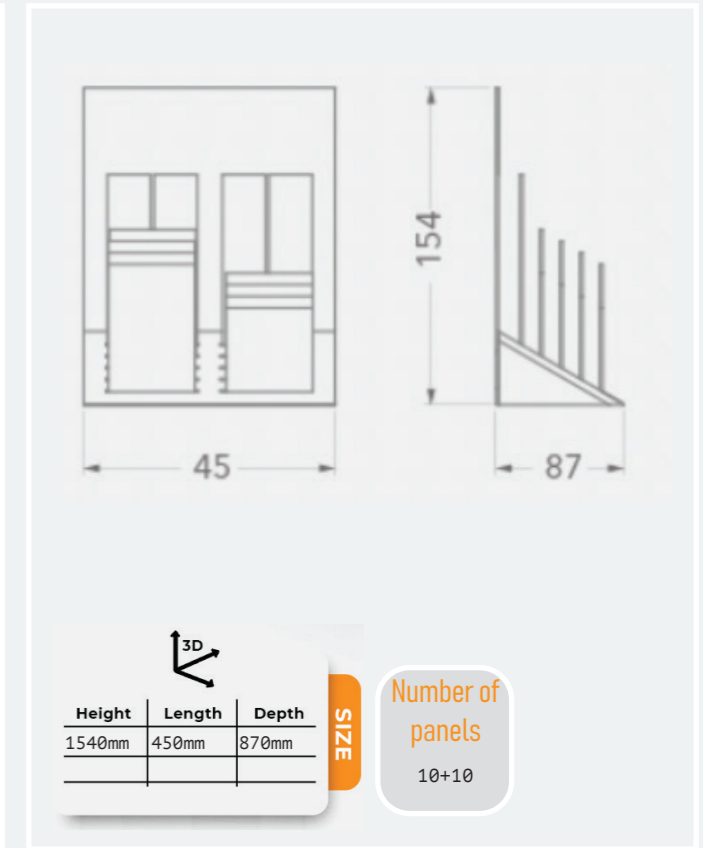

Solo-02

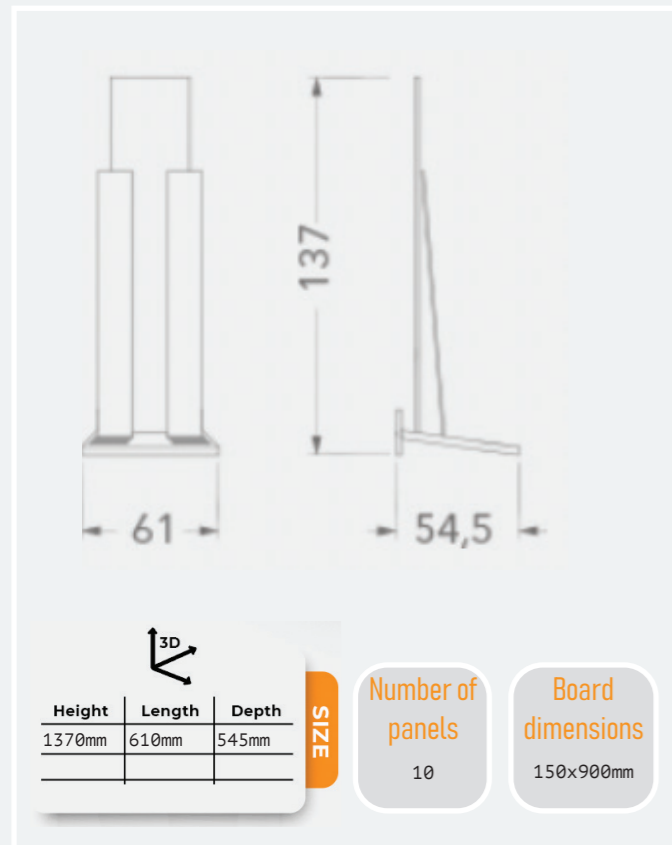

Solo-04

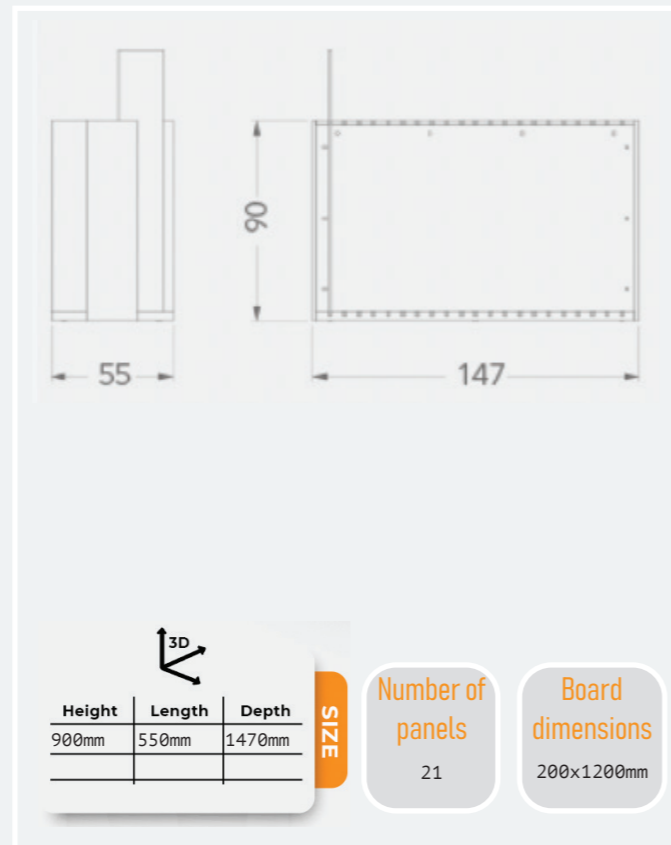

Mosaico

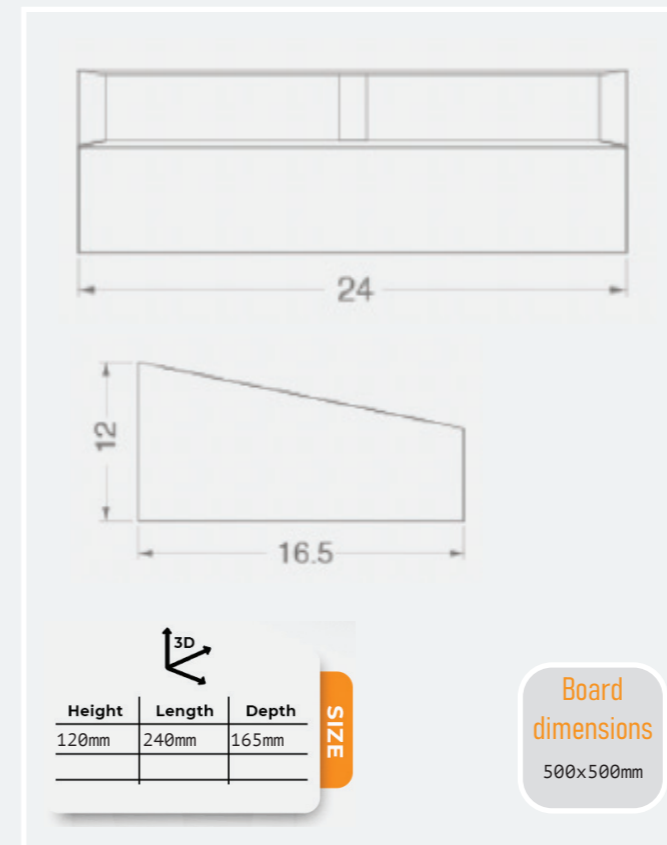

Back Print-01

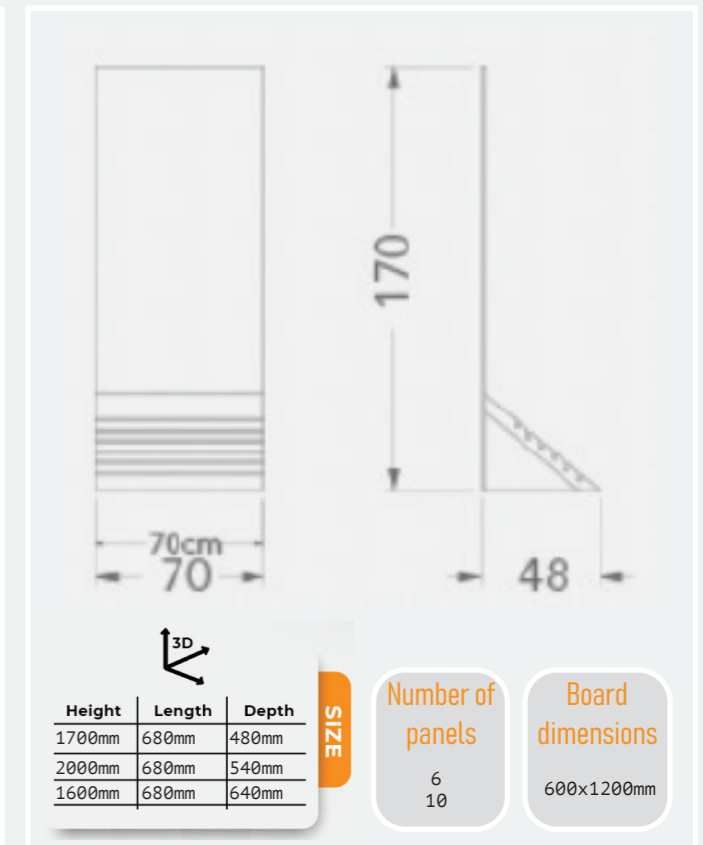

CRADLES

Back Print-03

Height	Length	Depth
1670mm	1230mm	520mm

SIZE

Number of panels
12

Board dimensions
600x600mm
400x1200mm

Back Print-04

Height	Length	Depth
1810mm	660mm	990mm

SIZE

Number of panels
14

Sanitary

Accessory-04

Height	Length	Depth
2400mm	2500mm	1220mm

SIZE

Number of panels
3

Board dimensions
1200x2090mm

Accessory-05

Height	Length	Depth
1900mm	900mm	450mm

SIZE

Ceramic-01

Height	Length	Depth
1100mm	500mm	780mm

SIZE

Number of panels
6

Board dimensions
600x600mm

Ceramic-02 / 03 / 04

Height	Length	Depth
60mm	900mm	1000mm
60mm	475mm	800mm
54mm	500mm	1000mm
55mm	460mm	250mm

SIZE

Number of panels
6
8
9

Board dimensions
1200x1200mm
475x800mm
690x1040mm